

This drawing contains confidential and/or privileged information. Any unauthorized copying, disclosure or distribution of the material in this drawing is strictly forbidden. Diese Zeichnung beinhaltet vertrauliche Informationen. Unerlaubte Vervielfältigung, Veröffentlichung oder Verbreitung dieser Informationen ist strengstens untersagt.

Parameter	Standard Mode
<b>Operating Data Clutch</b>	
Supply Voltage (rated)	28 V
Supply Voltage Range	24 ... 30 V DC
Rated Current <sub>1</sub> at rated voltage	1,1 A
Rated transmittable Torque <sub>2</sub> at rated voltage (without slippage)	30 Nm
Operating Temperature	-30 ... +40 °C
<b>Operating Data Servo</b> <i>(please see datasheet of DA 30-HT for more details)</i>	
Supply Voltage (rated)	28 V DC
Supply Voltage Range	12 ... 32 V DC
Standby Current <sub>1</sub> at rated voltage	<0,04 A
Rated Current <sub>1</sub> at rated voltage	2,0 A
Peak Current <sub>1</sub> at rated voltage	3,6 A
Rated Torque <sub>1</sub> at rated speed	18,0 Nm
Peak Torque <sub>1</sub> at rated voltage	32,0 Nm
No Load Speed <sub>1</sub> at rated voltage	165 °/s
Rated Speed <sub>1</sub> at rated torque	100 °/s
Max. Travel Angle <sub>3</sub>	±160° = 320° total travel
Backlash (mechanical)	≤ 0,6°
Position Error under Temperature <sub>4</sub>	≤ ±1°
Operating Temperature Range	-30 ... +70 °C
Storage Temperature Range	-55 ... +85 °C
Weight <sub>1</sub>	3250 g

- 1) Tolerance ±10%  
2) Tolerance ±20%

- 3) without clutch  
4) -20...+50°C, Δt=70°C

**Item No.:**

**DA 30-HT.MCCS.30.5848.3.MIL13**

- DA Digital Actuator
- 30 30mm Class
- HT High Torque Version
- MCCS Magnetic Clutch, Coaxial Shaft with internal Sensor
- 30 28-32V DC Power Supply
- 5848 Internal Number
- 3 RS 485 Command Interface
- MIL13 38999 13-pin MIL Connector

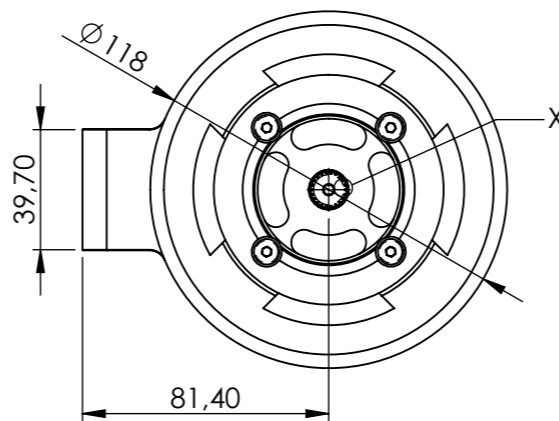
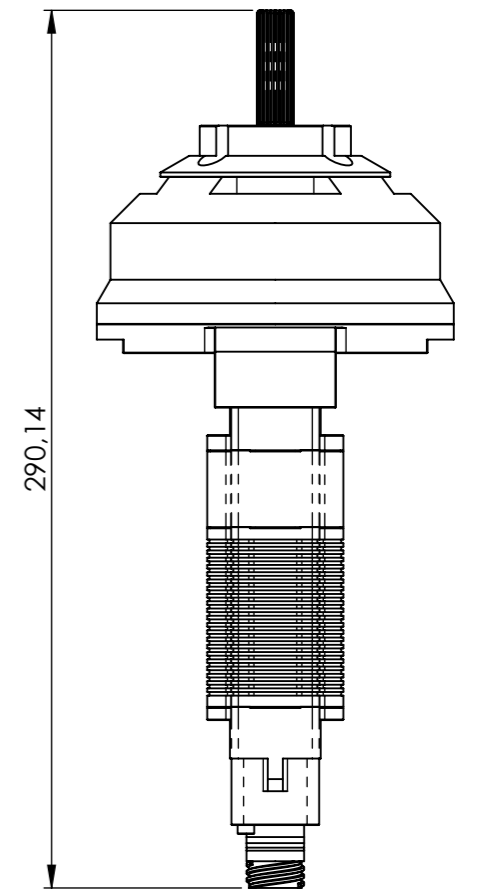
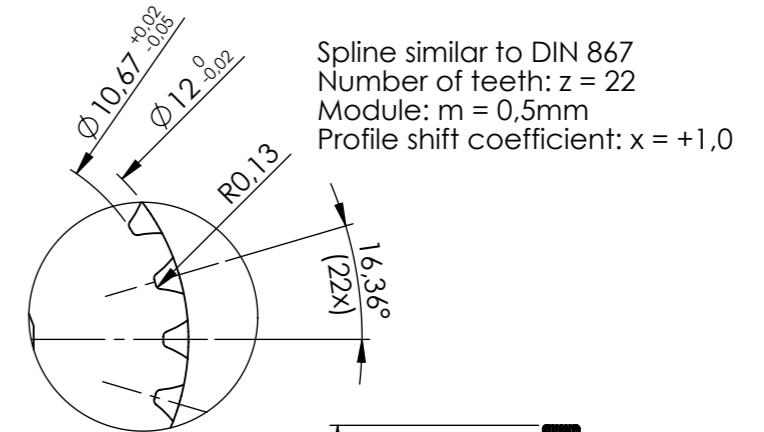
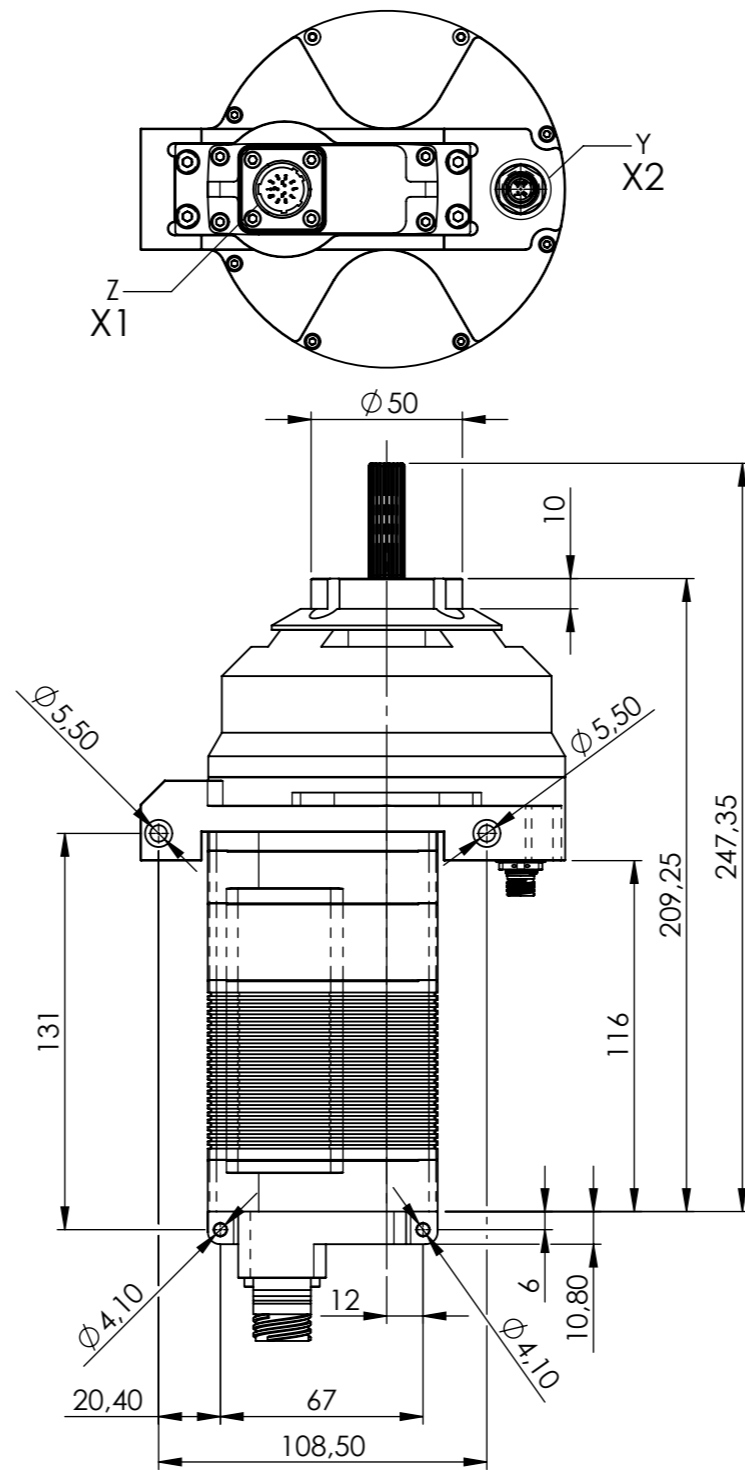
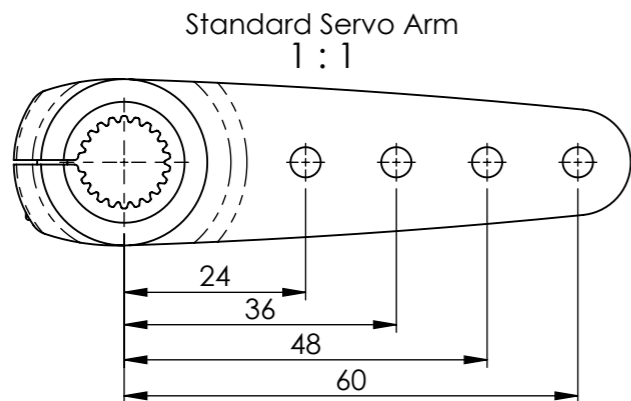

**Servo Case Surface Treatment: HART®-Coat**

Drawing not to scale / Zeichnung nicht maßstäblich		
<b>VOLZ</b> <b>Servos GmbH &amp; Co. KG</b>		
Heinrich-Krumm-Straße 5 63073 Offenbach Germany www.volz-servos.com		
Title / Benennung: <b>DA 30-HT-MCCS Configuration Control</b>		
Dwg. No. / Zch.-Nr.:	517-6000-12	Rev.: A
Scale / Maßstab: 1:2.5	Sheet / Blatt: 1/2	A3

Content is subject to change without notice

This drawing contains confidential and/or privileged information. Any unauthorized copying, disclosure or distribution of the material in this drawing is strictly forbidden.  
 Diese Zeichnung beinhaltet vertrauliche Informationen. Unerlaubte Vervielfältigung, Veröffentlichung oder Verbreitung dieser Informationen ist strengstens untersagt.

RS 485 Communication Parameters	
Baudrate 1	115200
No. of Data Bits	8
No. of Stop Bits	2
Parity	None
Data Frame	6 bytes
Max. Frame Rate	100 Frames per second
Signal Polarity	One = High , Zero = Low
Address Range	0x01 ... 0x1E

1) Other baudrate on request

RS 485 Command / Response Frame	
Byte #	Description
1	Command / Response-Code
2	Actuator ID
3	Argument 1
4	Argument 2
5	CRC High Byte
6	CRC Low Byte

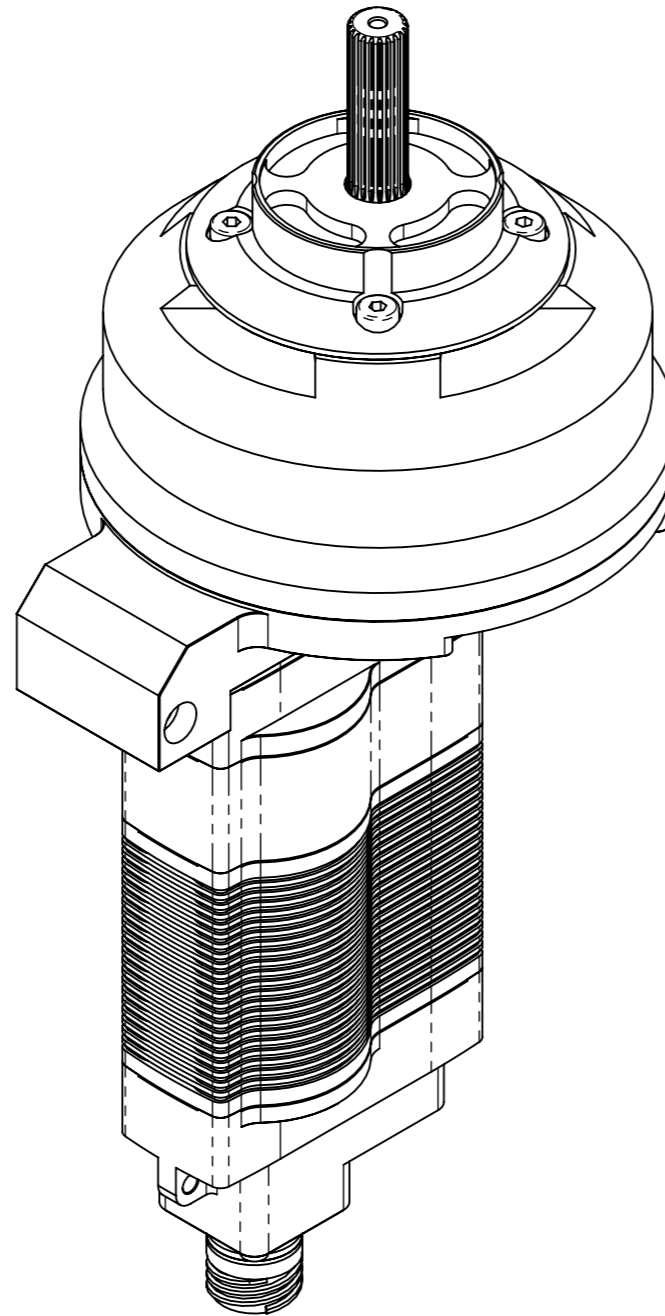

1 : 1.5

Amphenol  
38999-20WB35PN  
X1

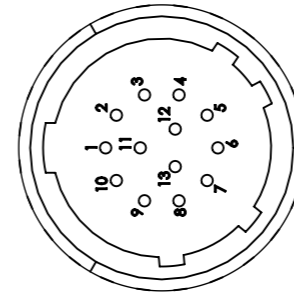

DETAIL Z  
2 : 1

Glenair MM  
801-009-07M6-4PA  
X2

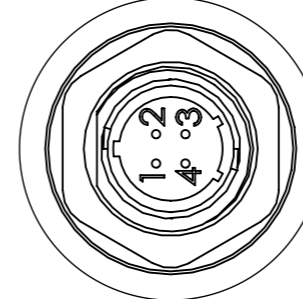

DETAIL Y  
2 : 1

Pin Assignment		
38999-20WB35PN (Detail Z) - X1		
1	NC	Do not connect
2	PWR_1	Power Supply Input 1
3	NC	Do not connect
4	COM1_A	COM1 A (RS 485)
5	COM1_B	COM1 B (RS 485)
6	CASE_GND_1	Case Ground
7	COM2_A	COM2 A (RS 485)
8	COM2_B	COM2 B (RS 485)
9	NC	Do not connect
10	PWR_2	Power Supply Input 2
11	NC	Do not connect
12	GND_1	Return, Signal Ground 1
13	GND_2	Return, Signal Ground 2
801-009-07M6-4PA (Detail Y) - X2		
1	GND_3	Clutch Engage Return
2	PWR_3	Clutch Engage Power
3	NC	Do not connect
4	NC	Do not connect

Drawing not to scale / Zeichnung nicht maßstäblich

**VOLZ Servos GmbH & Co. KG**  
 Heinrich-Krumm-Straße 5  
 63073 Offenbach  
 Germany  
 www.volz-servos.com

Title / Benennung: DA 30-HT-MCCS  
Configuration Control

Dwg. No. / Zch.-Nr.: 517-6000-12 Rev.: A

Scale / Maßstab: 1:2.5 Sheet / Blatt: 2/2 A3

Content is subject to change without notice